

Pressure Hulls and Canisters 3
Cornerstone Electronics Technology and Robotics III
Pressure Hulls and Canisters Lab 2 – Making a Plexiglas Pressure Canister

- **Purpose:** The students build pressure canisters for their class ROVs.
- **Apparatus and Materials:**
 - 1 – 4" x 4" x 1/2" Plexiglas (Lucite or Acrylic Glass)
 - 1 – 4" x 4" x 1/4" Aluminum
 - 1 – 3" OD x 2 3/4" ID x 7 1/8" Plexiglas Cylinder
 - 4 – 1/4-20 All-Tread, Cut to Mount onto Your ROV Frame
 - 8 – 1/4-20 Stainless Steel (SS) Nuts
 - 8 – 1/4-20 SS Washers
 - 1 – 4" x 4" Piece of Rubber Gasket (Home Depot Model #59849A)
 - Weld-On #3 Plastic Glue Cement for Acrylic
 - 1 – Plastic Glue Cement Syringe Applicator
 - 1 – Piece of Sandpaper or Emory Cloth 220, 400, and 600 Grit
- **Procedure:**
 - Mill each edge of the 4" x 4" x 1/4" aluminum and file off burrs.
 - Layout the hole pattern shown below on both the Plexiglas and aluminum end caps.

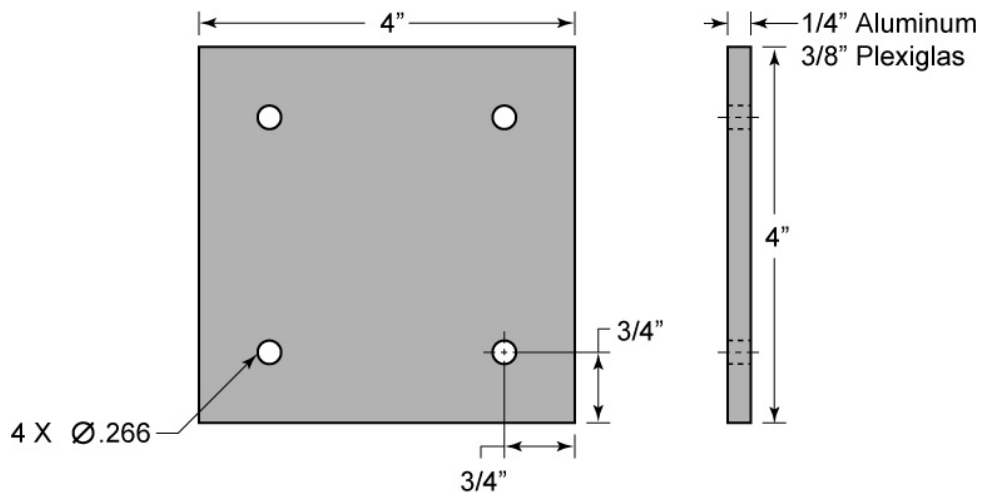

- Use an H drill bit (0.266") to drill the four holes.
- Smooth each end of the Plexiglas cylinder on the 220, 400, and 600 grit sandpaper placed on a flat surface.
- Center the 3" OD Plexiglas cylinder on the 4" x 4" Plexiglas. See below.

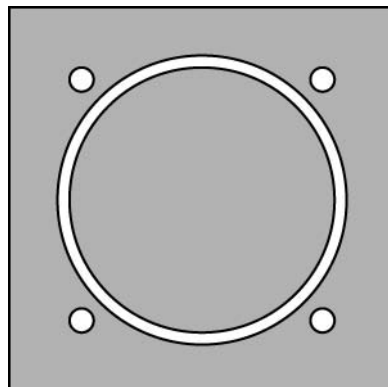

- Using the syringe, apply the Weld-On #3 plastic glue cement to the Plexiglas/Plexiglas junction inside and outside, allowing the cement to flow into the joint by capillary action. Allow a few seconds for the cement to soften the surfaces then apply weight on the cylinder to press parts firmly together.
- Follow the Weld-on #3 manufacturer's instructions for dry time before submerging the cylinder.
- Layout the lengths needed on the ¼-20 all-thread.
- Insert a nut for each side of a cut before you make the cuts. See the illustration below.

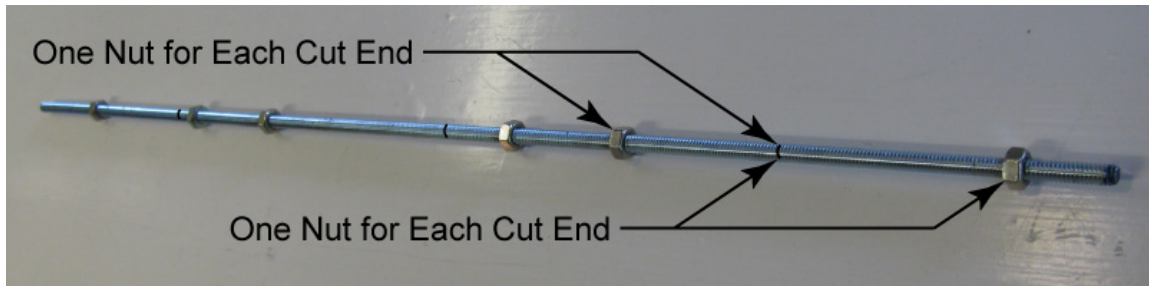

- Cut the pieces from the all-thread stock. Be careful not to damage the adjacent threads when making your cuts.
- Using a bench grinder, grind the cut ends square then put a slight chamfer by rotating the all-thread end lightly against the grinder stone.
- Now unscrew the nuts off each cut end of the all-thread pieces to remove burrs from the threading. See photos below.



- Cut the rubber gasket to a diameter slightly smaller than the hole pattern or leave it as a 4" x 4" square and punch holes where the all-threads will pass through.
- Insert weights into the cylinder. You may want to tape the weights so they won't scratch the Plexiglas.

- Place the rubber between the aluminum end cap and the cylinder then assemble the pressure canister as illustrated below. Tighten the nuts gradually the way you would tighten car tire lug nuts so the Plexiglas will not crack. Loosen in a similar manner.

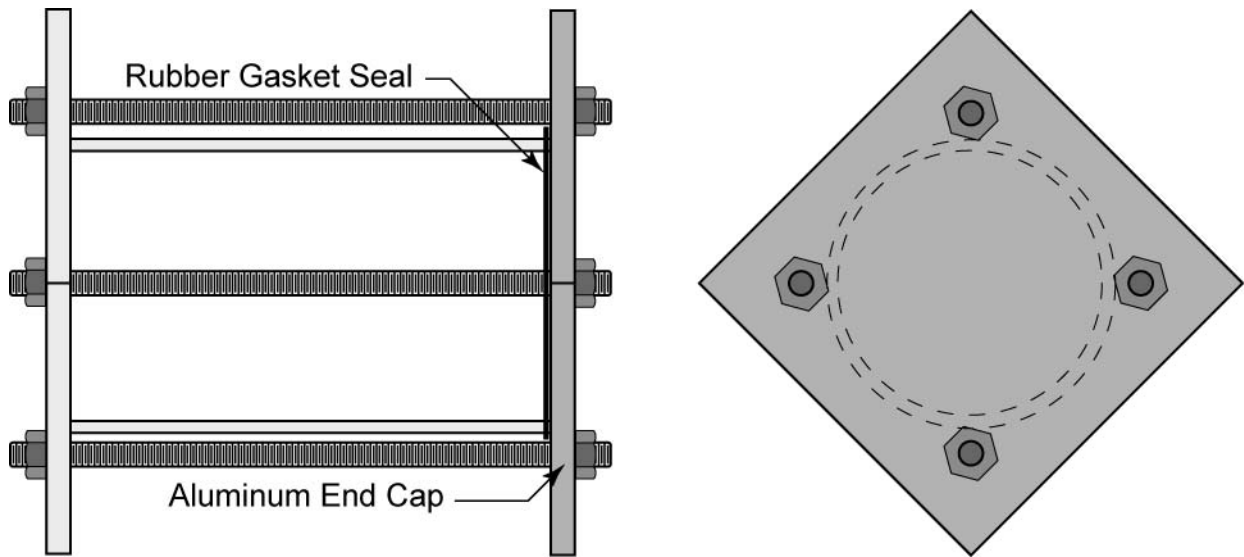

Final Pressure Canister Assembly Rotated 45 Degrees



Final Assemble of the a Shortened Pressure Canister Housing

- After the plastic cement drying period, place the weighted cylinder into the test pond until the next class.
- **Results:**
 - Did the pressure canister remain waterproof for the duration of the test? If not, what are corrections do you recommend?