

Power Systems 3

Cornerstone Electronics Technology and Robotics III

Notes primarily from "Underwater Robotics – Science Design and Fabrication", an excellent book for the design, fabrication, and operation of Remotely Operated Vehicles (ROVs)

- **Administration:**

- Prayer

- **Power Requirements for Your Underwater Vehicle:**

- Remember the difference between energy and power. Energy is the capacity of a physical system to perform work. Power is the rate at which work is performed or energy is transmitted. Energy is what is delivered and power is the rate at which it is delivered. A system onboard an ROV may consume more energy over time even though it does not demand as much power as another systems on board. Refer to Figure 1.

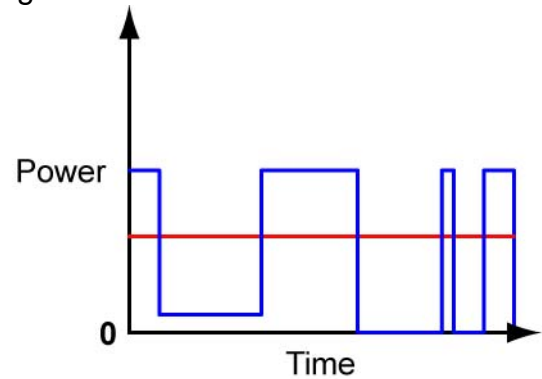
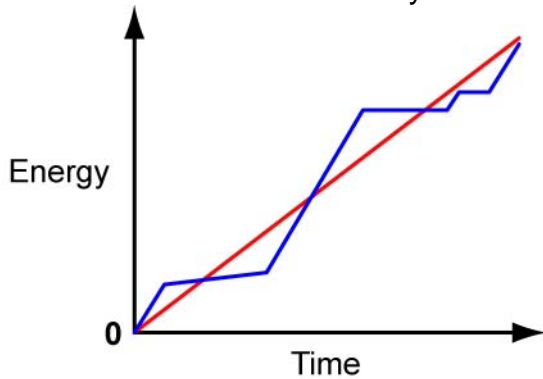

— Energy Consumed by Lights (watt-hours)

— Power Demand from Lights (watts)

— Energy Consumed by Propulsion (watt-hours)

— Power Demand from Propulsion (watts)

Figure 1: Graphs Showing the Energy and Power Consumed by Two Systems on an ROV during a Mission

- **Power for Propulsion:**

- A general rule of power consumption for small ROVs and AUVs. This rule is derived from empirical data for electric motor thrusters with well-matched propellers: At speeds less than 1 m/s, a small ROV or AUV will probably use 20 – 40 watts of electrical power per pound of thrust.

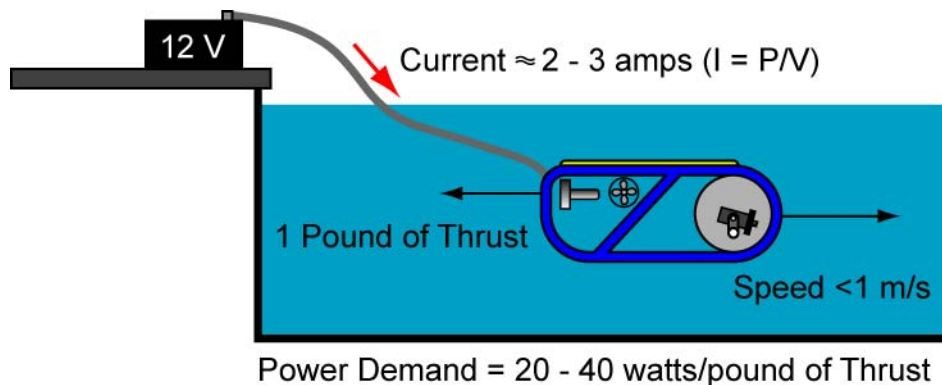

Figure 2: General Rule for Power Demand of Electrical Motor Thruster on a Small ROV

- Theoretical power demand for a vehicle at a fixed speed:

$$\text{Power} = \text{Drag} \times \text{Speed}$$

Where: Power in watts (1 watt = 1 j/s = 1 Nm/s)
 Drag in newtons
 Speed in m/s

- **Power Consumption for Other High-Power Systems:**

- Other small ROV systems that consume high power include motors for payloads, bright lights, and some cameras. Their power consumption will normally be consistent with their specifications. Remember that you can calculate power demand of a device knowing its required voltage and current draw, $P = V \times I$.

- **Power Budget:**

- A power budget summarizes the power consumption of your vehicle. The sample ROV power budget in Table 1 is for a 1.5 hour mission and is taken from the textbook.

Device	Number	Power/Device (Maximum)	Total Max Power	Max ON Time per Dive	Total Energy
Thruster Motors	4	9 watts	36 watts	1.5 hrs	54 watt-hr
Video Lights	2	25 watts	50 watts	1.5 hrs	75 watt-hr
Wireless Ethernet Network Switch	1	5 watts	5 watts	2 hrs	10 watt-hr
Video Camera	2	1.5 watts	3 watts	2 hrs	6 watt-hr
Camera Tilt Motor	1	9 watts	9 watts	negligible	negligible
Microcontroller	2	0.5 watts	1 watt	2 hrs	2 watt-hr
Lasers	2	1 watt	2 watts	1 hr	2 watt-hr
Misc. Sensors and Electronics	several	negligible	negligible	2 hrs	negligible
Totals			106 watts		149 watt-hr

Table 1: Sample Power Budget

- In the unlikely event that all the ROV devices turned on at one time, the “total maximum power” column provides the maximum power demand.
- The sum of the “total energy” is crucial for AUVs with on-board batteries that must carry their power source. When the sum is closely matched to the battery rating, read the battery specifications to make sure that the discharge rate and other factors do not affect the battery performance while on the mission.
- Notice that power-hungry devices do not automatically indicate that they consume a significant amount of energy, for example, the camera tilt motor. On the other hand, lower-power devices such as wireless Ethernet network switch may consume considerable energy.
- It is better to be conservative when you develop the power budget so that the vehicle will perform consistently while on its missions.

- **Electric Power Sources for Small Vehicles:**
 - There are two primary sources of electrical power to drive your vehicle, batteries or wall outlets. In the United States, electricity from the wall outlet is 115 VAC at 60 Hz. **This source is not recommended for most underwater vehicle projects, especially for beginners or school groups because of the danger of fatal electric shock.** Refer to the textbook for the dangers of AC power and safety procedures when working with AC electrical power. Though batteries have their own safety issues, they are usually safer when working around water and supply an excellent source of electrical power.
 - **Introduction to Batteries:**
 - Batteries offer several advantages in addition to their relative safety:
 - They are easy to find and relatively inexpensive.
 - They can store plenty of energy for operating a small underwater vehicle.
 - Most can be placed into positions other than right side-up.
 - Batteries are clean; they are not greasy or oily.
 - Running power through wires makes power distribution to the onboard systems easy.
 - Information regarding battery specifications and operation is readily available on the web or other sources.
 - Battery technology is evolving at a rapid rate because of consumer demand for smaller, lighter and more powerful batteries. This progress gives more options to the underwater vehicle designer.
 - What is a Battery? A battery stores chemical energy, which it converts to electrical energy.
 - A typical battery, such as a car battery, is composed of an arrangement of galvanic cells. Each cell contains two metal electrodes, separate from each other, immersed within an electrolyte containing both positive and negative ions. A chemical reaction between the electrodes and the electrolyte takes place. This gives rise to an electric potential between the electrodes, which are typically linked together in series and parallel to one another in order to provide the desired voltage at the battery terminals (for example, a 12 volt car battery).
 - Each galvanic cell develops a voltage from less than 1 volt to a maximum of 3 volts. Individual cells are interconnected to form a battery. For example, 6 - 1.5 volt alkaline batteries connected in series make up a 9 volt battery.



Figure 3: 6 – 1.5 Volt Cells Are Connected in Series to Form a 9 Volt Battery

- **Primary Batteries:** A cell in which an irreversible chemical reaction generates electricity; a cell that cannot be recharged (for one-time use).
 - Primary cells are also called dry cells. A dry cell is a cell in which the electrolyte is absorbed into a paper or made into a paste.

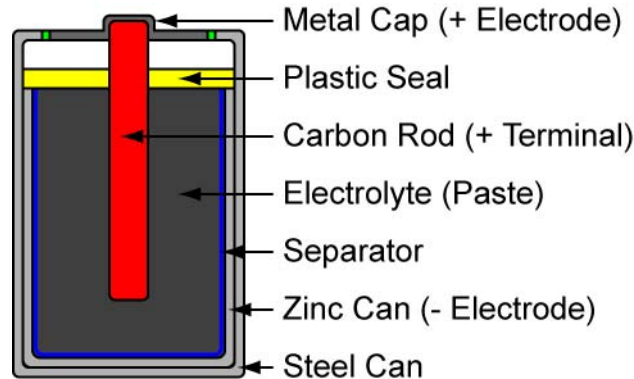

Figure 4: Primary Battery Construction (Carbon-Zinc Battery)

- Common used primary batteries are alkaline dry cells and lithium batteries.
- Perform Power Systems 3 Lab 1: Making a Dry Cell Battery
- **Secondary Batteries:**
 - A secondary battery is a battery that produces electric current through a chemical reaction which can be reversed; a secondary battery can be recharged.
 - A secondary cell can be recharged by forcing a current through the battery in the opposite direction of the discharge current.
 - Chemical formulas for lead-acid battery charging: http://openbookproject.net/electricCircuits/DC/DC_11.html

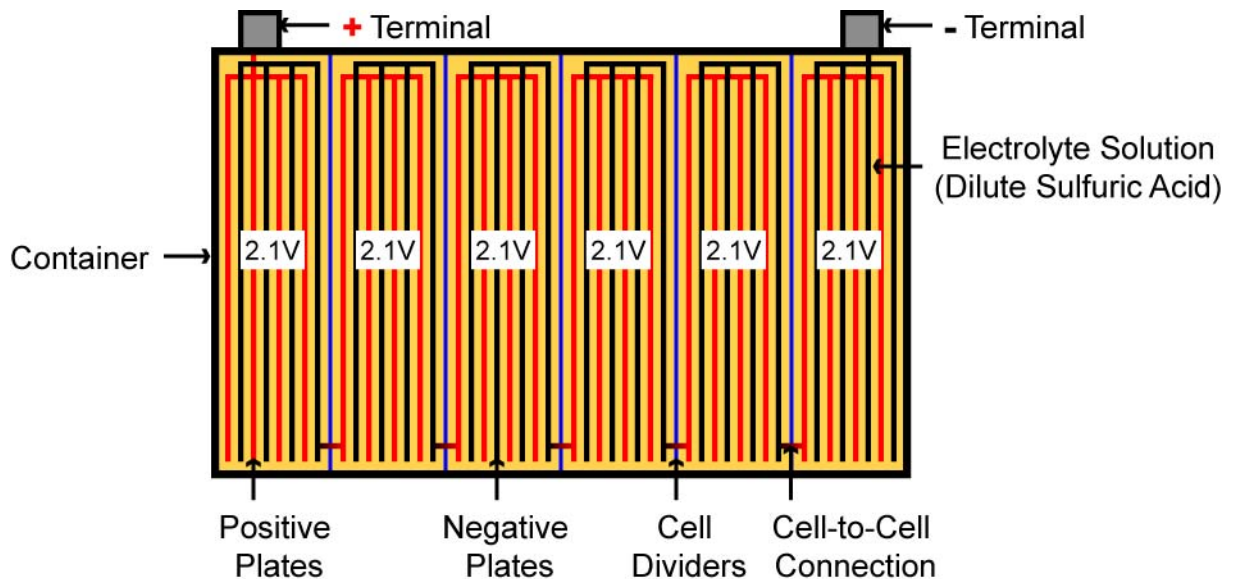

Figure 5: 12.6 Volt Lead-Acid Car Battery Internal Connections

- **Battery Safety:** Please refer to the textbook regarding this crucial topic.

- **Battery Performance Characteristics:**
 - **Voltage:**
 - Common battery voltages:
 - Familiar AAA, AA, C, and D are normally single-cell batteries with voltages between 1.2 and 1.5 volts.
 - The “transistor battery” supplies 9 volts.
 - Lead-acid batteries such as car batteries are 12 – 13.5 volts.
 - There are many specialty battery sizes and shapes for customized uses that furnish voltages from few volts to over 100 volts.
 - Be aware that nominal voltage on a battery may not be the actual voltage. For example, a 12 volt car battery may actually give 13.6 volts when fully charged and then drop off below 12 volts as it discharges.
 - No-load voltage: The voltage level present at the output terminals when a no load is applied. Most batteries are considered “dead” long before their no-load voltages reach zero volts. When a car battery with a no-load voltage of 10 volts is connected to a robust load, its voltage will fall significantly and act, in effect, as a dead battery.



Figure 6: Checking the No-Load Voltage of a Battery

- Internal resistance: If you use a voltmeter to measure the open circuit voltage of an AA size battery, you will find that the voltage is about 1.5 V. But if you are using a circuit to draw a large current from the battery, you will find that the voltage across the battery is less than 1.5 V. This is because the battery itself has an intrinsic resistance called internal resistance. One way to think of internal resistance is to imagine a real battery as being made up of an ideal battery of voltage V_i , connecting in series with a resistor R which represents the internal resistance (see Figure 7). When no current is drawn from the battery, the voltage drop across the battery is of course V_i , $V = V_i$. But when a current I is drawn from the battery, there is a voltage drop $I \times R$ across the resistor, so the voltage V across the battery is decreased to:

$$V = V_i - I R$$

Therefore, the larger the current drawn by the load, the smaller the voltage, V of the battery. The internal resistance of a battery is usually quite small.

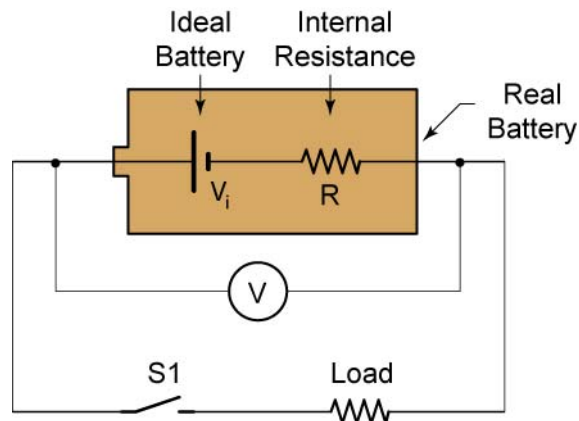

Figure 7: Representing Internal Resistance in a Battery

An experiment that measures the internal resistance of a battery is found at: http://www.hk-phy.org/energy/commercial/act_int_resist_e.html

- Multiple voltage requirements: All of the electrical systems on a vehicle may not function at the same voltage. For example, microcontroller control circuits normally work at 3.3 or 5 VDC, while thrusters operate in general at higher voltages such as 12 or 24 VDC. One way you can supply different voltages to the vehicle is by providing separate batteries for each voltage level. Another method is to choose a battery rated at the highest voltage needed, and then reduce the high voltage for the lower voltage circuits using voltage regulators or DC-to-DC converters.

- **Primary Versus Secondary Batteries:**
 - The initial cost of primary batteries is typically less than secondary batteries; however, they cannot be recharged. Over the lifetime of a project, the replacement cost for primary batteries can exceed the higher initial cost of rechargeable secondary batteries.
- **Energy Capacity:** The total amount of useful energy stored in a battery.
 - The energy capacity of large batteries is specified in amp-hours, smaller batteries in milliamp-hours. Although amps x time is not a valid energy unit, it is a convenient unit for battery capacity. Amp-hours are the product of amps multiplied by hours. For example,

$$1 \text{ amp-hour} = 1 \text{ amp} \times 1 \text{ hour}$$

$$1 \text{ amp-hour} = 5 \text{ amp} \times 0.2 \text{ hour}$$

$$1 \text{ amp-hour} = 10 \text{ amp} \times 0.1 \text{ hour}$$

$$200 \text{ amp-hour} = 50 \text{ amp} \times 4 \text{ hour}$$

A battery with a capacity of 1 amp-hour should ideally be able to continuously supply a current of 1 amp to a load for exactly 1 hour before becoming completely discharged. In summary, the higher the Ah rating, the longer the battery will last.

- Calculating the energy capacity of a battery in watt-hours (a valid energy unit):

$$\text{Energy Capacity} = \text{Power} \times \text{Time}$$

Since Power = Voltage x Current,

$$\text{Energy Capacity} = \text{Voltage} \times \text{Current} \times \text{Time}$$

For example, if a 12 V battery is rated at 5 amp-hours, the capacity in watt-hours is:

$$\text{Energy Capacity} = 12 \text{ V} \times 5 \text{ Ah}$$

$$\text{Energy Capacity} = 60 \text{ Wh}$$

- **Caution #1:** The actual number of amp-hours a battery supplies is dependent upon the level of current draw from the battery. The manufacturer specifies the length of discharge time for their battery. For example, a lead-acid battery discharge time is frequently 20 hours. If your discharge rate is faster than the specified rate, the actual amp-hours delivered will be less than the battery rating.

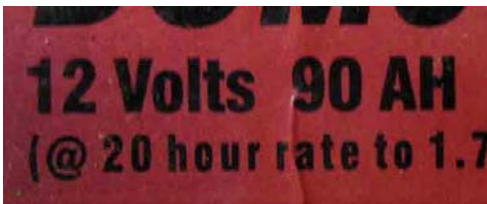

Figure 8: Lead-Acid Battery with a 20-Hour Discharge Rate

- Caution #2: Different manufacturers have different definitions for a “dead battery”. This will affect the actual amp-hours the battery will deliver.
- **Energy Density:** Refer to the textbook.
- **Weight:** Refer to the textbook.
- **Maximum Power Output (Power Capacity):**
 - Remember, power is the rate at which work is done or energy is transferred. It is the work/time or energy/time ratio. A battery may have enough stored energy for your mission, yet it may not have sufficient power capacity to supply the power demand that your ROV requires.
 - The maximum discharge current a battery can provide is sometimes called the “surge current” (in amps).
 - C-rate (units of per hour) is another form of stating the maximum current. It is a conversion factor to convert the amp-hour rating into the maximum current. A battery with an Ah rating of 4 and a C-rating of 6 can deliver a maximum current of $4 \text{ Ah} \times 6/\text{h} = 24 \text{ A}$. The higher the C-rating, the higher the maximum current output available.
- **Discharge Curves:**
 - Batteries lose voltage in the process of discharge their energy. Discharge curves plots the drop in voltage as the capacity is depleted.

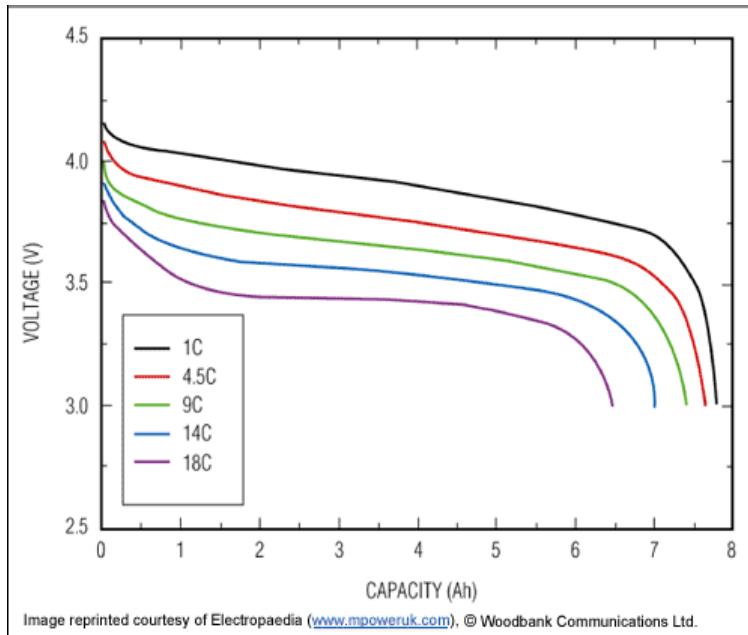

Figure 9: Battery Discharge Curve for a Lithium Ion Battery

Each line on the graph is the voltage (V) as the capacity (Ah) is expended at a constant current.

Current at 1C = $8\text{Ah} \times 1/\text{hr} = 8 \text{ A}$.
 Current at 18C = $8 \text{ Ah} \times 18/\text{hr} = 144 \text{ A}$.

The energy capacity of the battery is reduced as the constant current draw is increased.

From: <http://www.maxim-ic.com/app-notes/index.mvp/id/3958>

- **Depth of Discharge:** The amount of energy that has been removed from a battery (or battery pack).
 - Usually expressed as a percentage of the total capacity of the battery. For example, 50% depth of discharge means that half of the energy in the battery has been used.
 - Some batteries, such as car batteries, are not made to be discharged very much before they must be recharged. Others batteries, called deep-cycle batteries, can be drained deeply without being damaged. These batteries are more appropriate for underwater vehicle applications where energy is needed throughout the mission and recharging occurs after the mission is completed.
- **Maximum Charge Rate:** Refer to the textbook.
- **Temperature Performance:** Be aware that battery performance typically drops as the temperature decreases.
- **Size and Shape:** Refer to the textbook.
- **Shelf Life:** Refer to the textbook.
- **Required Maintenance:** Refer to the textbook.
- **Ease of Acquisition and Disposal:** Refer to the textbook.
- **Price:** Refer to the textbook.

- **Series and Parallel Battery Combinations:**

- You can add to your voltage, energy capacity, or maximum power output by connecting two or more batteries in series, parallel, or a combination of series and parallel.
- Case 1, Higher Voltage – Batteries in Series:

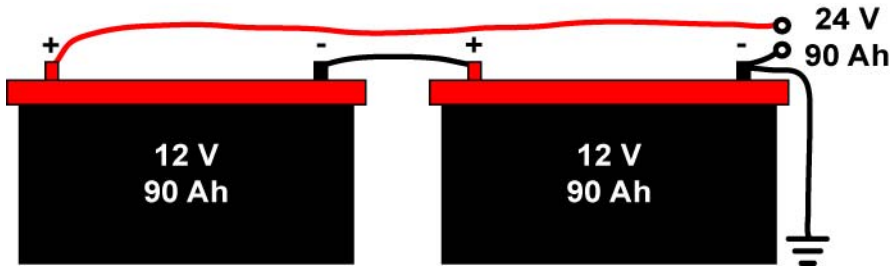

Figure 10: Batteries in Series:

Voltages add, but the energy capacity and peak current output remain the same.

- Case 2, Higher Energy Capacity and Maximum Current Output – Batteries in Parallel:

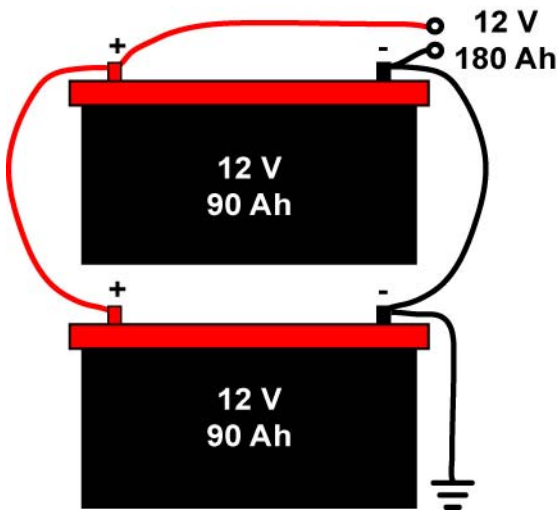

Figure 11: Batteries in Parallel:

Voltage remains the same, energy capacity and peak current outputs add.

- Case 3, Higher Voltage, Energy Capacity and Maximum Current Output – Batteries in Combination of Series and Parallel:

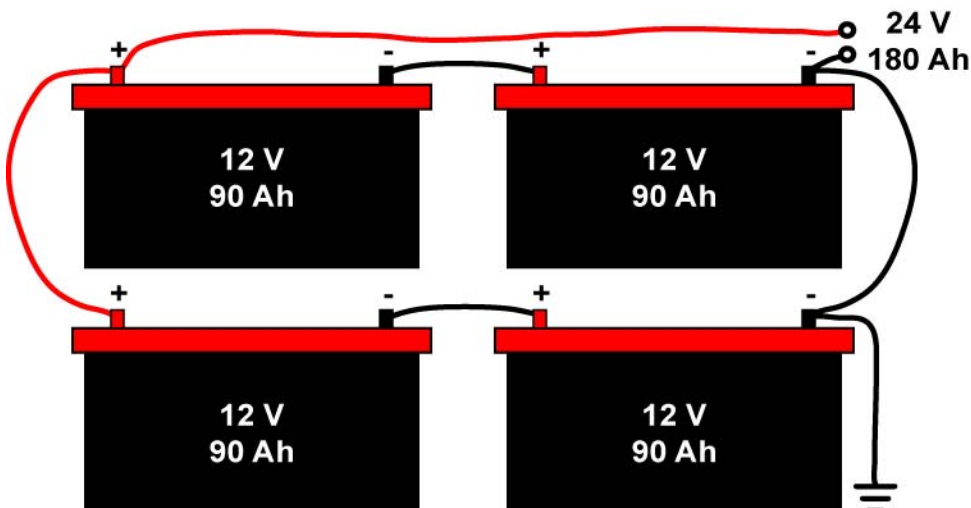

Figure 12: Batteries in Combination:

Voltages add in the series section, energy capacity and peak current output add in the parallel section. **Caution – Keep voltages below 15 volts around wet conditions.**

- Safety and performance considerations when combining batteries:
 - Minimize the possibility of electrocution by keeping voltages below 15 volts around wet conditions.
 - Fire and explosions are possible with improper battery combinations. See textbook for an example.
 - The main reason to avoid mix batteries is reduced performance. Current flow through batteries in series is limited by the weakest cell.
 - For peak performance and safety, always use fully charged batteries of the same size, type, age, voltage, and manufacturer when connecting batteries in series and parallel.
- Perform Power Systems 3 Lab 2: Batteries in Series and Parallel.
- **Battery Choices:**
 - Alkaline Cells:
 - Readily available worldwide
 - Relatively inexpensive
 - Good performance
 - Available in several standardized sizes, AAA, AA, C, and D
 - Voltage from each cell is normally 1.5 volts
 - Most are not rechargeable
 - Less popular for ROV applications due to high battery energy draw.
 - Sealed Lead-Acid Batteries:
 - Use same galvanic chemistry as car batteries
 - The electrolytic is non-spillable
 - Can be placed in any orientation including upside-down
 - Equipped with a valve to relieve internal pressure especially when recharging
 - AGM (Absorbed Glass Mat) batteries are a good choice for a ROV power source.
 - Widely available
 - Easily recharged
 - Relatively inexpensive
 - Nickel Metal Hydride Cells (NiMH) and Nickel-Cadmium Cells (Ni-Cad):
 - Voltage from each cell is 1.2 volts
 - Nickel metal hydride cells are replacing the nickel-cadmium cells which have the memory effect problem.
 - NiMH batteries cost more than Ni-Cad batteries and have half the service life.
 - NiMH batteries hold 30% more storage and discharge capacity than Ni-Cad batteries.
 - NiMH batteries can be used to supply currents up to 30 amps.
 - Ni-Cads provide greater peak power output and a lower price than NiMHs.
 - Also available in several standardized sizes, AAA, AA, C, and D

- Lithium Batteries:
 - Lithium battery technology is under rapid development, so the information below is subject to change.
 - This battery type includes Lithium-ion (Li-ion) and Lithium polymer (Li-poly).
 - Commonly used in laptop computers and cell phones.
 - One of the best energy-to-weight ratios of any battery
 - No memory effect
 - Slow charge loss when stored
 - Available in both primary and secondary forms
 - Advantages of Lithium polymer over Lithium-ion batteries:
 - Less expensive to produce
 - Contain higher energy
 - Lighter
 - More flexible in shape and size
 - Current disadvantages of lithium batteries:
 - Readily catch fire if damaged, if charged or discharged incorrectly, or if their inner parts are exposed to air or water
 - Can burn rapidly and violently
 - They begin to age as soon as they are manufactured
 - The charge/discharge cycle is lower than NiMH, non-spillable lead-acid, and Ni-Cad batteries
 - Can suddenly fail
 - Can absorb oil in oil-filled housings
 - Li-poly must never be discharged below a set voltage to avoid irreversible damage
 - Connecting Li-poly in combinations creates a serious risk for fire

Cornerstone Electronics Technology and Robotics III Power Systems 3 Lab 1 – Making a Dry Cell Battery

- **Purpose:** The student assembles a dry cell battery from a kit.
- **Apparatus and Materials:**
 - 1 – Digital Multimeter
 - 1 – IASCO Dry Cell Kit from Industrial Arts Supply Company
See: http://www.iasco-tesco.com/index.php?page=shop.product_details&flypage=flypage.tpl&product_id=646&category_id=30&keyword=dry+cell&option=com_virtuemart&Itemid=2
- **Procedure:**
 - Following the instructions in the kit, assemble the dry cell battery.



IASCO Dry Cell Kit

- Measure and record the voltage generated from your battery.

Cornerstone Electronics Technology and Robotics III Power Systems 3 Lab 2 – Batteries in Series and Parallel

- **Purpose:** The purpose of this lab is to acquaint the student with how voltages add when placed in series and parallel.
- **Apparatus and Materials:**
 - 1 – Digital Multimeter
 - 4 – AA Batteries and Battery Holders
 - TBD – Potatoes
 - TBD – #16 hot-dipped galvanized nail
 - TBD – # 6 bare copper wire
 - 1 – LED
 - Alligator Leads
- **Procedure for Series Batteries:**
 - Connect the four AA batteries as shown in the schematic.

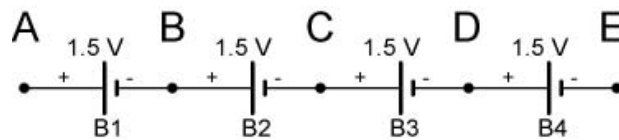

Batteries in Series

- Measure and record the voltages V_{AB} , V_{BC} , V_{CD} , and V_{DE} .
 - Calculate the voltages V_{AC} , V_{AD} , and V_{AE} then measure and record the same voltages.
 - Compare the calculated and measured results in the conclusions.
- **Results for Series Batteries:**

Individual Voltage	Measured	Added Voltage	Calculated	Measured
V_{AB}		V_{AB}	-	
V_{BC}		V_{AC}		
V_{CD}		V_{AD}		
V_{DE}		V_{AE}		

- **Procedure for Parallel Batteries:**
 - Connect the four AA batteries as shown in the schematic and measure V_{AB} .

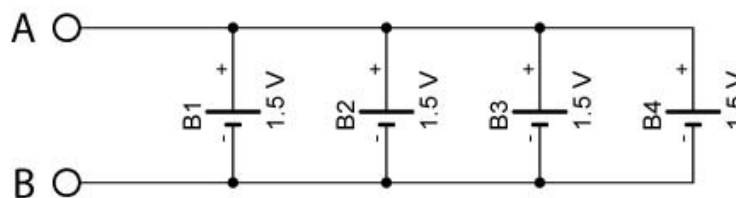

- Remove one battery at a time and measure and record V_{AB} .

- **Results for Parallel Batteries:**

V_{AB} Measured	Batteries Connected
	B1, B2, B3, B4
	B1, B2, B3
	B1, B2
	B1

- **Procedure for Parallel and Series Batteries:**

- Take a potato and insert a #16 hot-dipped galvanized nail and a # 6 bare copper wire to create a “potato cell”.
- Experiment to find a combination of potato cells in series and parallel that provides enough voltage and current to light an LED.

- **Results for Parallel and Series Batteries:**

- Draw the schematic of the battery layout used to light the LED.

- **Conclusions:**

- Dry cell Batteries in Series:
 - Compare the calculated and measured results in the batteries in series experiment.
 - Do the experimental results conform to the formula for batteries in series?
- Batteries in Parallel:
 - Do the experimental results conform to the formula for batteries in parallel?